

This installation guide is valid for the following models:
NORDUS G2 – NSS / NSSW



PRIOR TO INSTALLATION



Read all instructions to prevent injury, electric shock or damage due to fire or mechanical hazards
See product label for supply specifications



Inspect the luminaire and associated parts for any signs of defect, in particular fasteners, cables and the diffuser or glass lens

DO NOT INSTALL THE LUMINAIRE IF IT APPEARS IN ANY WAY FAULTY

Consult with the supplier / sales office for details regarding replacement



CAUTION



Before commencing installation, turn off and isolate the electrical supply

Electronic control equipment must not be subjected to high voltages. **DO NOT MEGGER** between Live and Neutral

All cable / conduit terminations must be installed in accordance with the designated IP rating of this product

Suitable installation fastening methods should be employed to ensure the mounting points are not damaged when subjected to vibration and / or movement

This luminaire must be installed by qualified electrician in accordance with local rules and codes

This luminaire cannot be disassembled by non-professional persons

If the external flexible cable or cord of this luminaire is damaged, it shall be exclusively replaced by the manufacturer or his service agent or a similar qualified person in order to avoid a hazard

The light source contained in this luminaire shall only be replaced by the manufacturer or his service agent or a similar qualified person

Maintain luminaire and driver clearance distance and also clearance distance from building parts as per local requirements or in accordance to AS/NZS 3000, whichever is greater. **WARNING - RISK OF OVERHEATING OR FIRE IF THE CLEARANCE DISTANCES ARE COMPROMISED**

Installation

Warning: This installation may be performed by 2 persons or more.

1. Turn OFF the main supply.

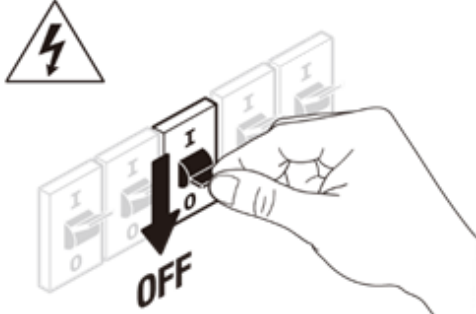

2. Place the luminaire on flat surface. Loosen the screws and separate the frame from the casing by disconnect safety lanyards and dismantle earth wire.

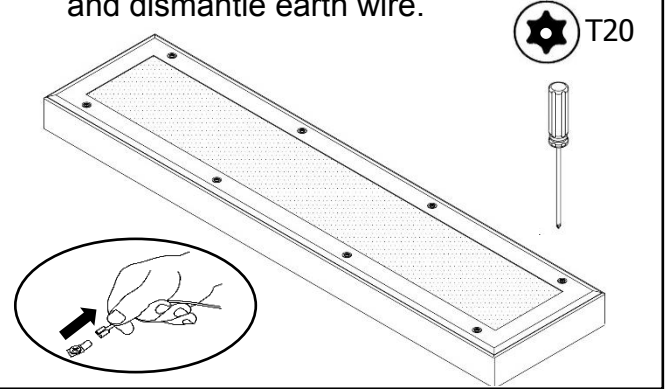

3. Loosen the screw on the LED tray, slide out the LED tray, disconnect safety lanyards and place it aside.

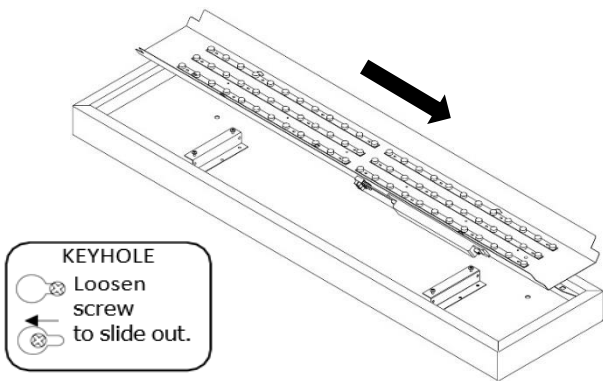

4. Bring the power cable in through the cable entry provided then mount the body.

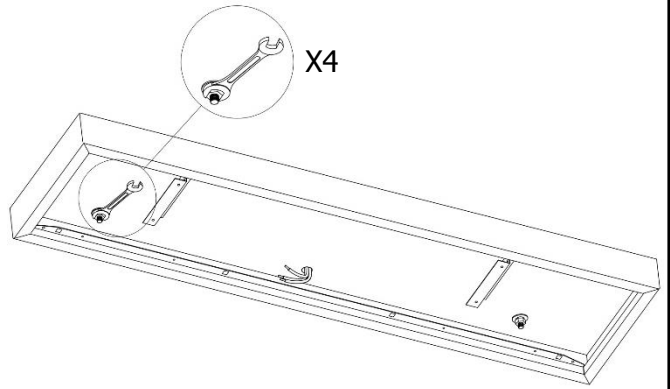

5. Hang the LED tray to the body. Connect the mains cable to terminal block located at the side of LED tray.

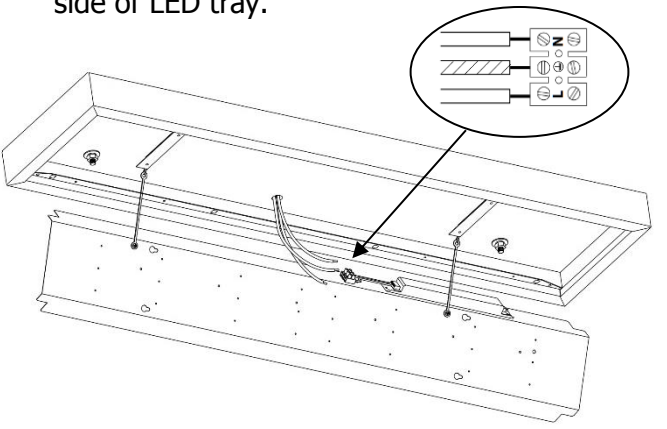

6. Tighten back the LED tray to the body and re-install the frame.

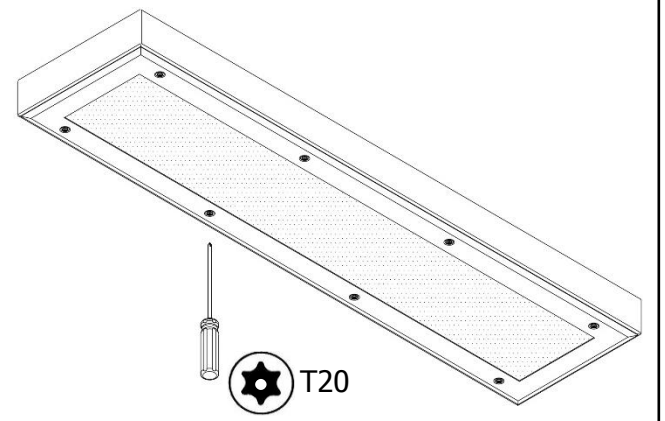

7. Turn ON the main supply.

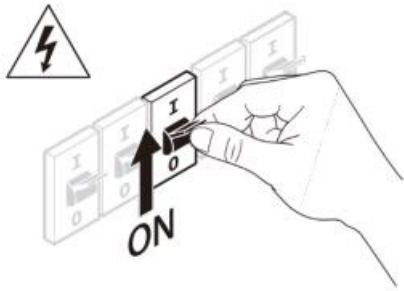

Unauthorized modification & improper installation void product warranty.

DIMENSIONS

NSS4/NSS2

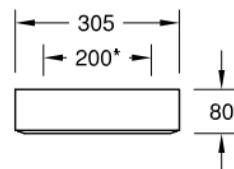
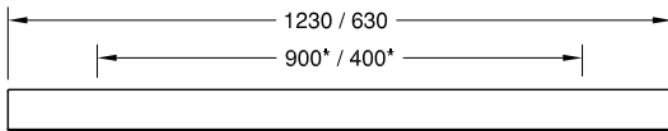
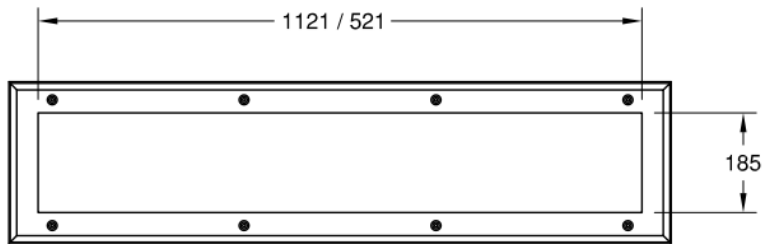

*Ø10mm mounting holes

NSSW

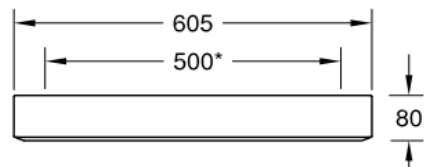
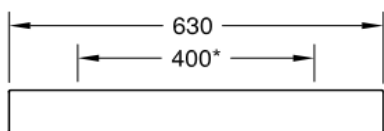
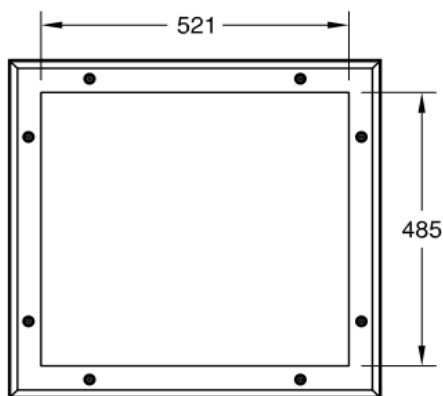

*Ø10mm mounting holes

MAINTENANCE

The supply must be isolated before opening or accessing the luminaire. Product maintenance is critical to the products designed performance. Davis Lighting is not responsible for any product not maintained in accordance with the recommended procedure or intervals. It is recommended that a bi-annual cleaning cycle is implemented. Inspect optical surfaces for damage or crack. Products supplied with visors or covers must not be operate with a damaged visor or cover; it is recommended damaged visors or covers be replaced by a competent person immediately. Seals and electrical components such as wirings to be checked for deterioration.



All photometric and electrical data published are of $\pm 10\%$ tolerance. Characteristics and specifications may change without notice. All electrical installations / connections should be carried out by a suitably qualified person. Application images are indicative only and may not contain actual Davis product. The information contained in this publication is typical and must not be interpreted as a guarantee of individual product performance.

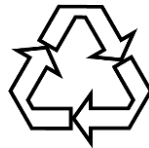

This product may contain substances that can be hazardous to the environment if not disposed of correctly. Electrical and electronic equipment should never be discarded along with general waste but should be separated for correct treatment and recovery. Packaging and waste materials should be recycled wherever possible.