

This installation guide is valid for the following models:

- Warell - WLS

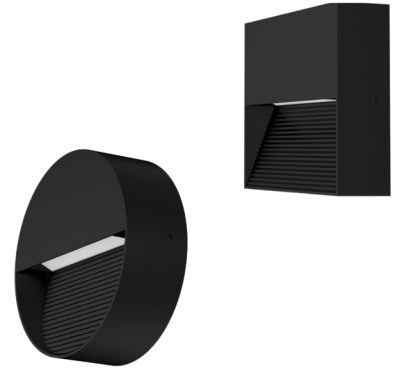

## PRIOR TO INSTALLATION



- Read all instructions to prevent injury, electric shock or damage due to fire or mechanical hazards
- See product label for supply specifications



Inspect the luminaire and associated parts for any signs of defect, in particular fasteners, cables and the diffuser or glass lens

**DO NOT INSTALL THE LUMINAIRE IF IT APPEARS IN ANY WAY FAULTY**

Consult with the supplier / sales office for details regarding replacement



## CAUTION



- Before commencing installation, turn off and isolate the electrical supply
- Electronic control equipment must not be subjected to high voltages. **DO NOT MEGGER** between Live and Neutral
- All cable / conduit terminations must be installed in accordance with the designated IP rating of this product
- Suitable installation fastening methods should be employed to ensure the mounting points are not damaged when subjected to vibration and / or movement
- This luminaire must be installed by qualified electrician in accordance with local rules and codes
- This luminaire cannot be disassembled by non-professional persons
- The light source of this luminaire is not replaceable; when the light source reaches its end of life the whole luminaire shall be replaced
- Prior to installation, products are to be stored in cool dry conditions

# INSTALLATION

1. Turn OFF the main supply

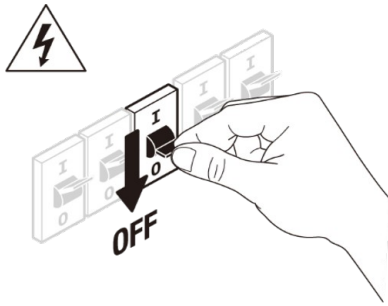

2. Separate casing from the base

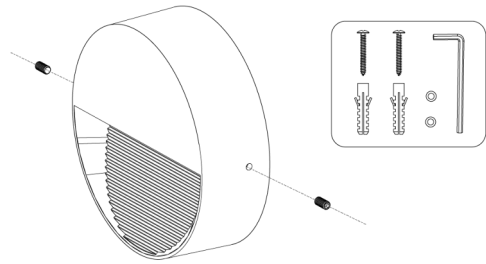

3. Use mounting bracket as guide, prepare wall plug, then mount the base

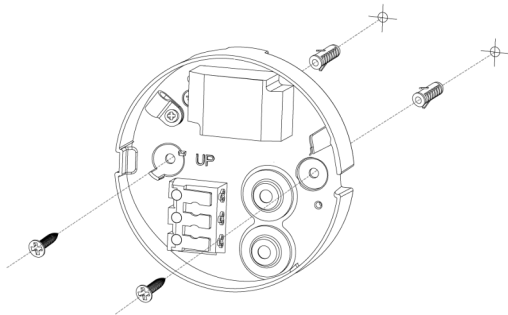

4. Connect mains cable to terminal block

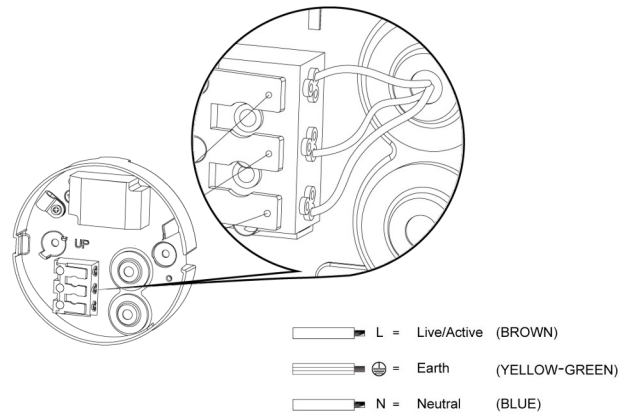

5. Install casing back to the base

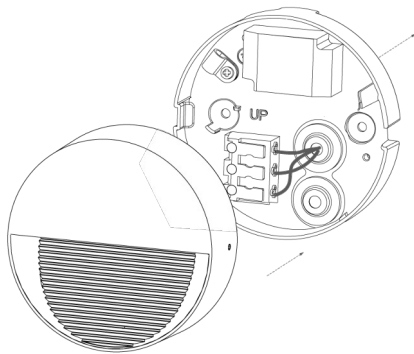

6. Turn ON the main supply

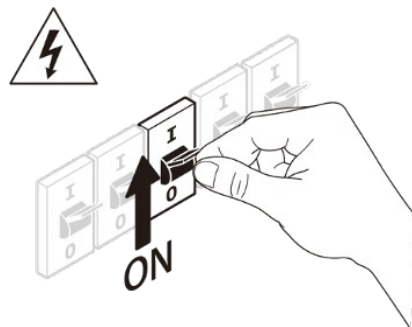

7. The wall light will be lit

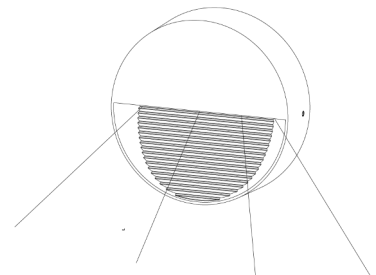



Unauthorized modification & improper installation void product warranty.

## DIMENSIONS

WLS5R

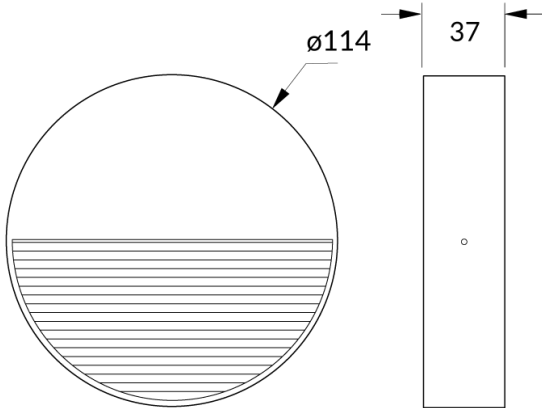

WLS8R

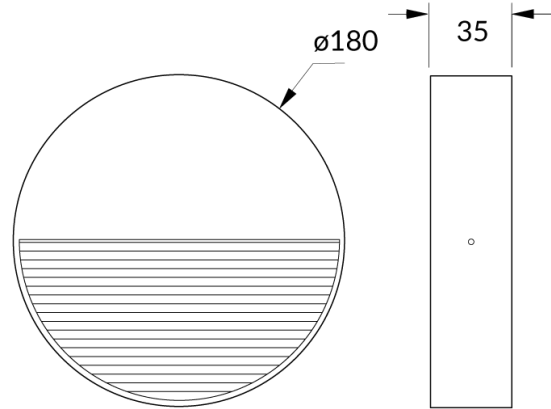

WLS5S

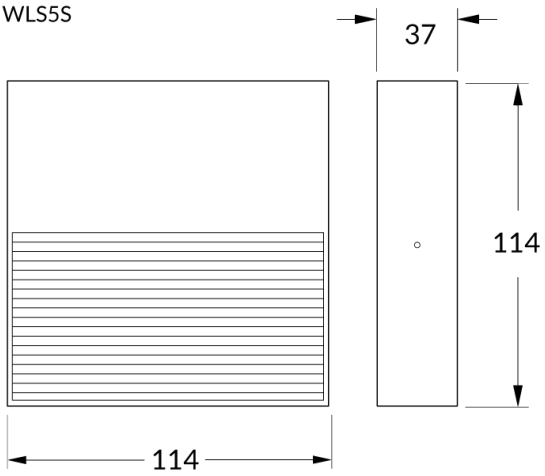

WLS8S

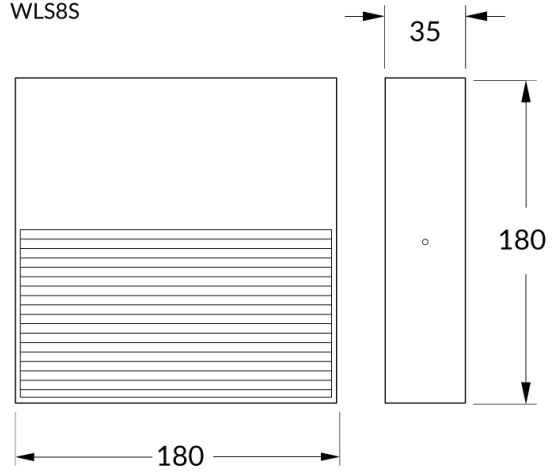

WLS5E

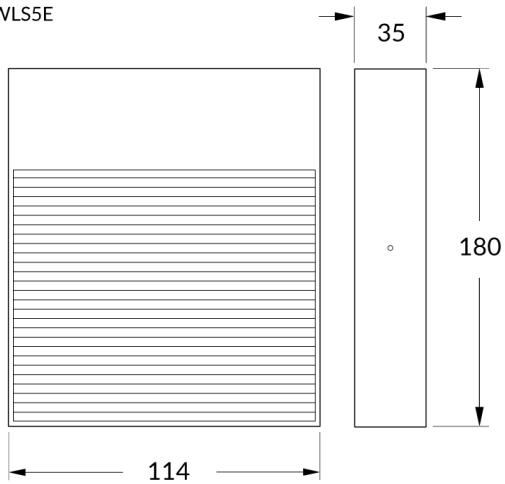

WLS10E

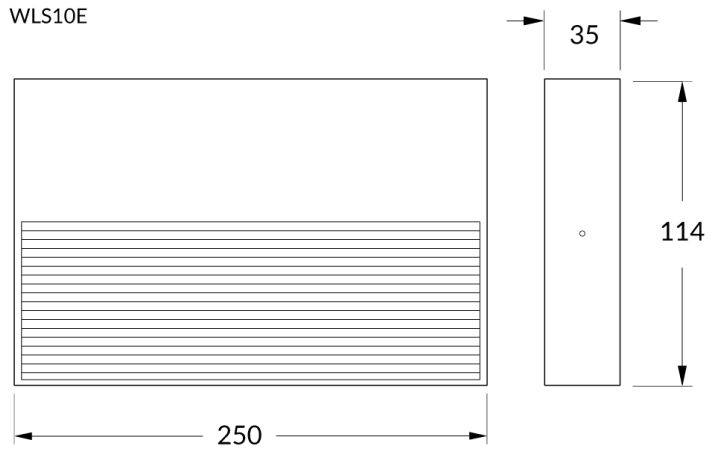



Unauthorized modification & improper installation void product warranty.

## MAINTENANCE

The supply must be isolated before opening or accessing the luminaire. Product maintenance is critical to the products designed performance. Davis Lighting is not responsible for any product not maintained in accordance with the recommended procedure or intervals. It is recommended that a bi-annual cleaning cycle is implemented. Inspect optical surfaces for damage or crack. Products supplied with visors or covers must not be operate with a damaged visor or cover; it is recommended damaged visors or covers be replaced by a competent person immediately. Seals and electrical components such as wirings to be checked for deterioration.



All photometric and electrical data published are of  $\pm 10\%$  tolerance. Characteristics and specifications may change without notice. All electrical installations / connections should be carried out by a suitably qualified person. Application images are indicative only and may not contain actual Davis product. The information contained in this publication is typical and must not be interpreted as a guarantee of individual product performance.

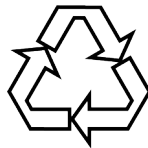

This product may contain substances that can be hazardous to the environment if not disposed of correctly. Electrical and electronic equipment should never be discarded along with general waste but should be separated for correct treatment and recovery. Packaging and waste materials should be recycled wherever possible.