



## Installation Instruction

### LARISSA GEN 2 LED WALLPACK

#### Models:

LA30

LA50



- Read all instructions prior to installing
- See product label for supply specification

#### DIMENSION:

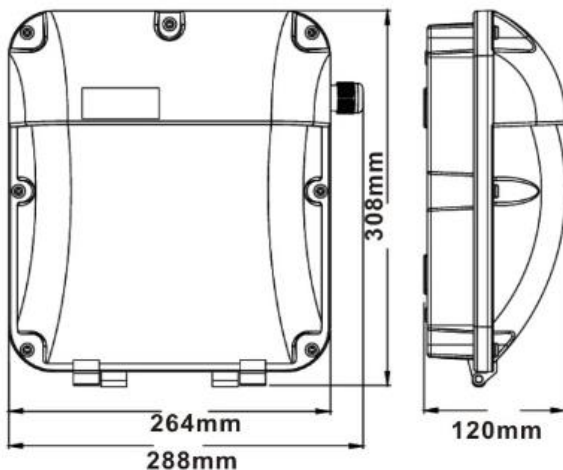

#### CAUTIONS:

- Installation is to be completed by a competent licensed electrician, in accordance with these instructions and relevant local regulations.
- Electronic control equipment must not be subjected to high voltages, DO NOT MEGGER between Live and Neutral.
- All cable/conduit terminations must be installed in accordance with the designated IP rating of this product.
- Suitable installation fastening methods should be employed to ensure the mounting points are not damaged when subjected to vibration and or movement.
- As is the case with all electronic components, it is advisable to fit appropriate surge protection to final sub circuits.
- Choose an installation place capable to withstand 10 times the weight of the product to ensure safety.

## INSTALLTION:

1. Remove cover by loosening all the screws.

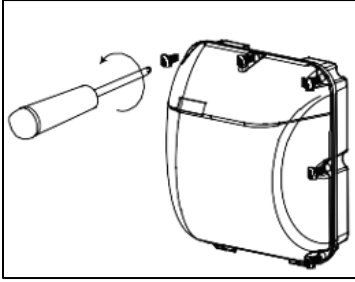

2. Mark and drill holes on wall. Insert wall plug as supplied.

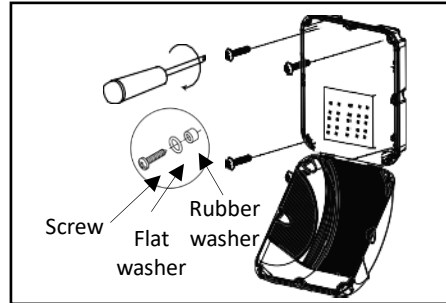
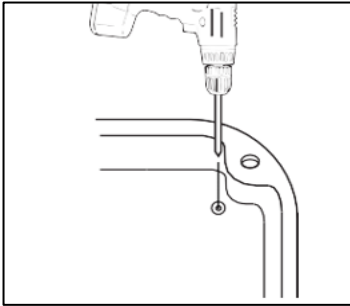

3. Connect cable Live (Brown), Neutral (Blue) and Earth (Yellow/Green) to the terminal block. Close cover and tighten all screws.

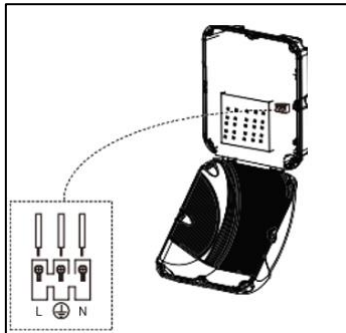

## MAINTENANCE:

The supply must be isolated before opening or accessing the luminaire. Product maintenance is critical to the product designed performance. The product is to be maintained in accordance with the manufacturer's instructions. For the latest product maintenance guides please go to [www.davislighting.com](http://www.davislighting.com). Davis Lighting is not responsible for any product not maintained in accordance with the recommended procedure or intervals. For recommended LAMP / LED maintenance guides, please refer to the lamp installation guidelines supplied with the lamp product or the nominated lamp manufacturer's website. Products supplied with visors or covers must not be operate with a damaged visor or cover; it is recommended damaged visors or covers be replaced by a competent person immediately.

**Warning: Maximum loading of earth leakage and circuit protection device.**

### Note

- The maximum number of ballasts/drivers connected to earth leakage circuit protection device shall not be greater than 6 units for fixed output on MCB 16A or that as recommended by the protective device supplier/manufacturer whichever is the smaller number.
- The maximum loading of automatic circuit breakers shall not be greater than those shown in the table supplied by the control gear manufacturer or that as recommended by the protective device supplied/manufacturer whichever is the smaller number.

