

This installation guide is valid for the following models:

- Bola - BAB



PRIOR TO INSTALLATION



- Read all instructions to prevent injury, electric shock or damage due to fire or mechanical hazards
- See product label for supply specifications
- Suitable for recessed or suspension mounting



Inspect the luminaire and associated parts for any signs of defect, in particular fasteners, cables and the diffuser or glass lens

DO NOT INSTALL THE LUMINAIRE IF IT APPEARS IN ANY WAY FAULTY

Consult with the supplier / sales office for details regarding replacement





CAUTION





- Before commencing installation, turn off and isolate the electrical supply
- Electronic control equipment must not be subjected to high voltages. **DO NOT MEGGER** between Live and Neutral
- All cable / conduit terminations must be installed in accordance with the designated IP rating of this product
- Suitable installation fastening methods should be employed to ensure the mounting points are not damaged when subjected to vibration and / or movement
- This luminaire must be installed by qualified electrician in accordance with local rules and codes
- This luminaire cannot be disassembled by non-professional persons
- If the external flexible cable or cord of this luminaire is damaged, it shall be exclusively replaced by the manufacturer or his service agent or a similar qualified person in order to avoid a hazard
- The light source of this luminaire is not replaceable; when the light source reaches its end of life the whole luminaire shall be replaced
- Prior to installation, products are to be stored in cool dry conditions

INSTALLATION

Packing List

Base plate		1 pc
Fixing plate		1 pc

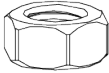
Screw M5x16		5 pcs
L Bolt M8		3 pcs
Nut M8		3 pcs

1. Install L bolts to fixing plate.

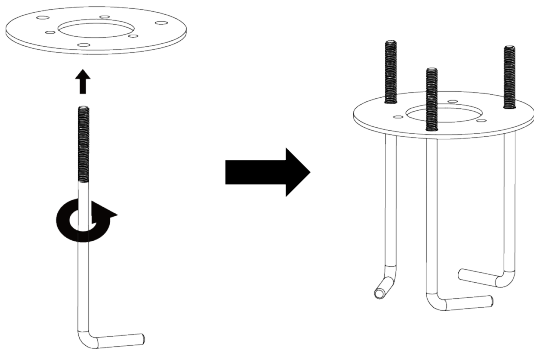

2. Prepare cement base & plant fixing plate.

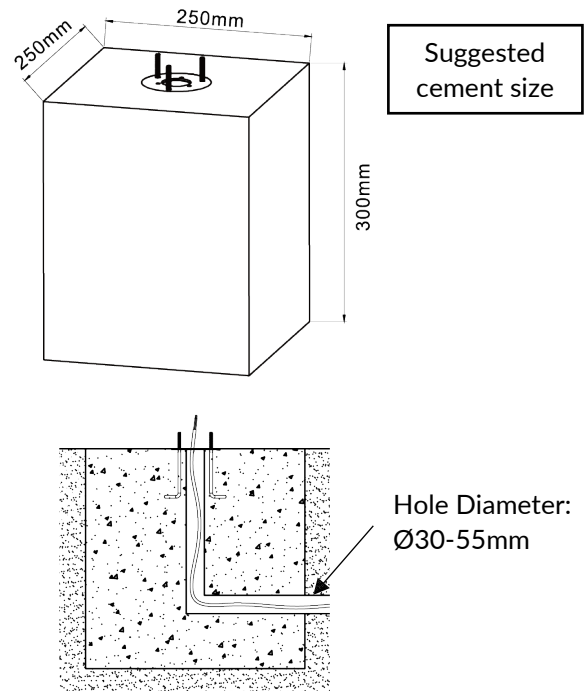

3. Install base plate to the fixing plate & tighten it with the nuts.

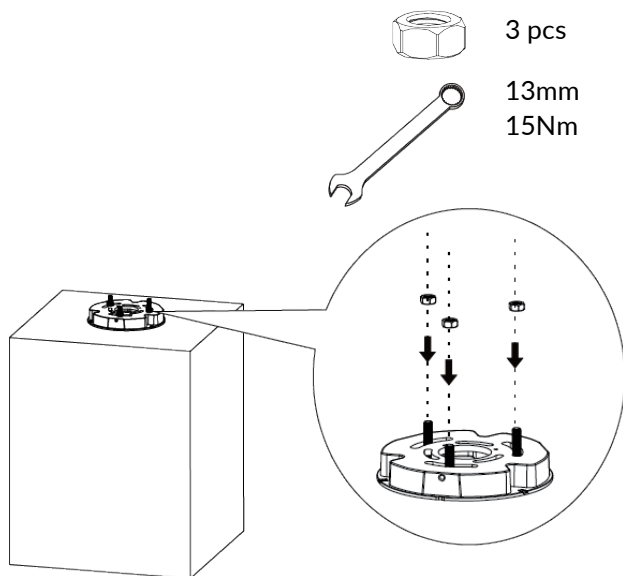

4. The direction of light should be on both side of notch.

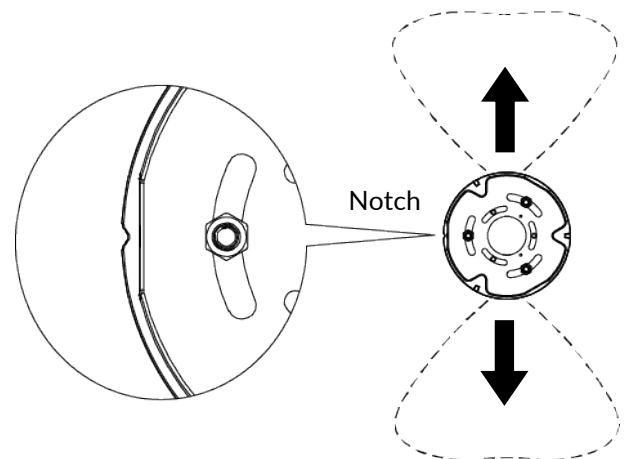

5. Install top head into the body & tighten with screws.

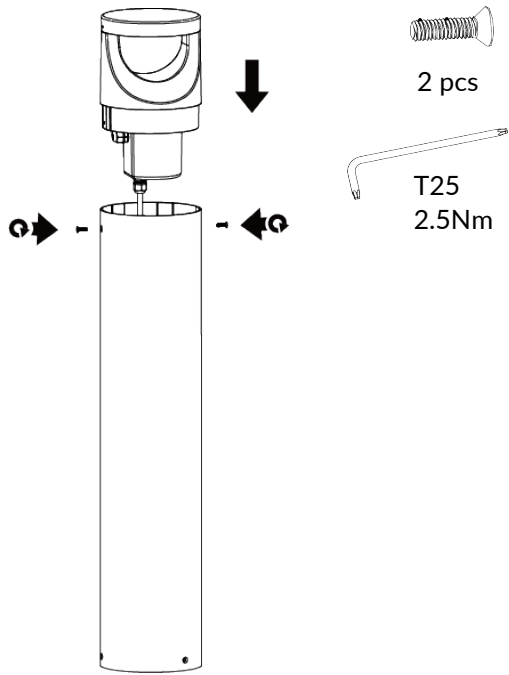

6. Connect mains cables with IP65 connector (not supplied).

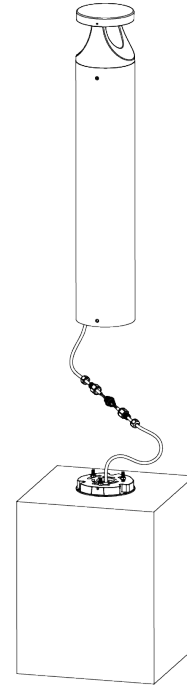

7. Install bollard to the base plate & tighten with screws.

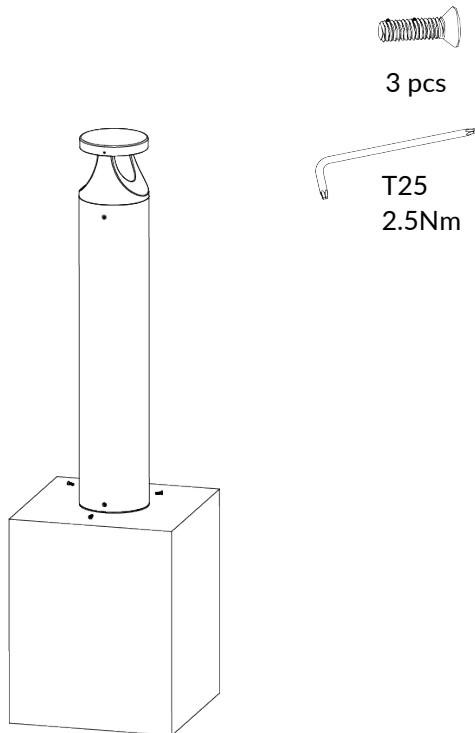

WIRING

L	brown	black
N	blue	white
Ⓞ GND	yellow/green	green

	Dimmable			
DIM+ / DA1	blue	brown	purple	white
DIM- / DA2	white	blue	gray	black



Warning!
Do not wire dim cord to high voltage or dim function will fail

DIMENSIONS

BAB1550 / BAB2550

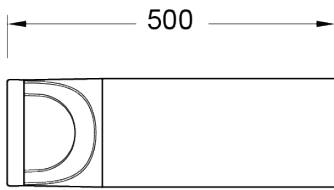

BAB1590 / BAB2590

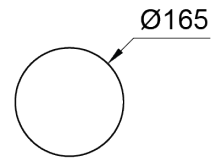
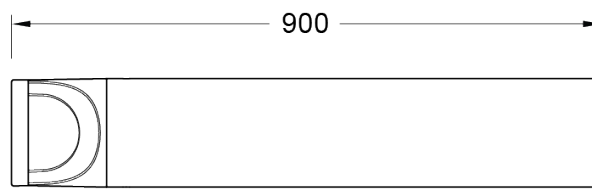

MAINTENANCE

The supply must be isolated before opening or accessing the luminaire. Product maintenance is critical to the products designed performance. Davis Lighting is not responsible for any product not maintained in accordance with the recommended procedure or intervals. It is recommended that a bi-annual cleaning cycle is implemented. Inspect optical surfaces for damage or crack. Products supplied with visors or covers must not be operate with a damaged visor or cover; it is recommended damaged visors or covers be replaced by a competent person immediately. Seals and electrical components such as wirings to be checked for deterioration.



OPTIONAL

All photometric and electrical data published are of $\pm 10\%$ tolerance. Characteristics and specifications may change without notice. All electrical installations / connections should be carried out by a suitably qualified person. Application images are indicative only and may not contain actual Davis product. The information contained in this publication is typical and must not be interpreted as a guarantee of individual product performance.

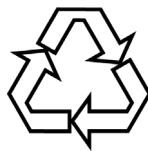

This product may contain substances that can be hazardous to the environment if not disposed of correctly. Electrical and electronic equipment should never be discarded along with general waste but should be separated for correct treatment and recovery. Packaging and waste materials should be recycled wherever possible.

CONTACT

Australia Head Office & Sales

Davex Australia Pty Ltd
Head Office: +61 (7) 3712 8988
Sales Offices: 1300 851 001
Fax: +61 (7) 3272 8988
Email: australia@davislighting.com

Malaysia Head Office & Sales

Davex Malaysia Sdn Bhd (114942-X)
Phone: +60 (3) 5636 4348
Fax: +60 (3) 5636 4352
Email: malaysia@davislighting.com

Singapore Head Office & Sales

Davex Singapore Pte Ltd
Phone: +65 6745 2511
Fax: +65 6745 5828
Email: singapore@davislighting.com