



## Features

- Enhanced performance
- Durable die-cast aluminium construction
- White powdercoat finish
- Clear glass lens (frosted shown)
- Tilt-adjustable to 60°
- Remote non-dimmable driver
- 0.6m flex and 2-pin plug

## Applications

- Retail shops
- Bars
- Restaurants
- Galleries
- Display areas

## Standards

Manufactured to the following standards:

- IEC/AS/NZS 60598.1
- IEC/AS/NZS 60598.2.1
- IEC/AS/NZS 60598.2.2
- IEC/AS/NZS CISPR 15

## Mounting Methods



Recessed



## Specifications

Model	RSL120150W4K
Nominal Power (w)	50
Supply Voltage	220 - 240 VAC 50 / 60 Hz
Luminous Flux (lm)	6000
Efficacy (lm/W)	120
Power Factor	>0.95
CRI	>80
Colour Temp. (K)	4000
LED Life L70B50 (hr)	50,000
Beam Angle (°)	60 x 90
Operating Temp. (° C)	-20 to +45

## Lighting Data

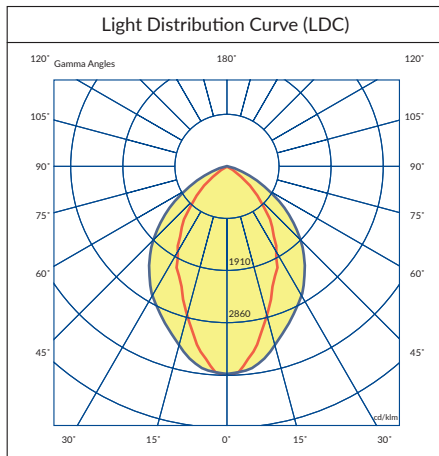

## Dimensions

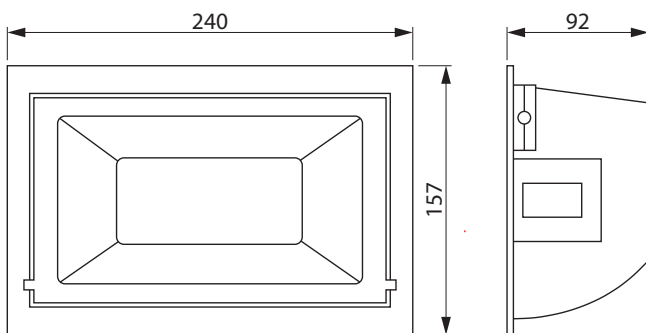

cutout 230 x 127



All photometric and electrical data published are of  $\pm 10\%$  tolerance. Characteristics and specifications may change without notice. All electrical installations / connections should be carried out by a suitably qualified person. Application images are indicative only and may not contain actual Davis product. The information contained in this publication is typical and must not be interpreted as a guarantee of individual product performance.