



### Features

- Recessed mounting
- Die-cast aluminium construction
- High quality powdercoat finish
- Adjustable pan (350°) and tilt (45°)
- Non-dimmable remote driver
- Quick and easy installation

### Applications

- Retail outlets
- Bars
- Restaurants
- Galleries
- Display areas

### Standards

- Manufactured under ISO 9001:2015 to standards
- IEC/AS/NZS 60598.1
- IEC/AS/NZS 60598.2.1
- IEC/AS/NZS 60598.2.2
- IEC/AS/NZS CISPR 15

### Mounting Methods



Recessed



## Specifications

<b>Model</b>	<b>LD36142W3K01B06</b>
Nominal Power (w)	42
Input Voltage	200 - 240 VAC 50 / 60 Hz
Luminous Flux (lm)	3300 ± 5%
Efficacy (lm/W)	85
CRI	≥80
Pan / Tilt (°)	350 / 45
Colour Temp. (K)	3000
Beam Angle (°)	60
LED Life L70B50 (hr)	>35,000
Colour	White

## Lighting Data

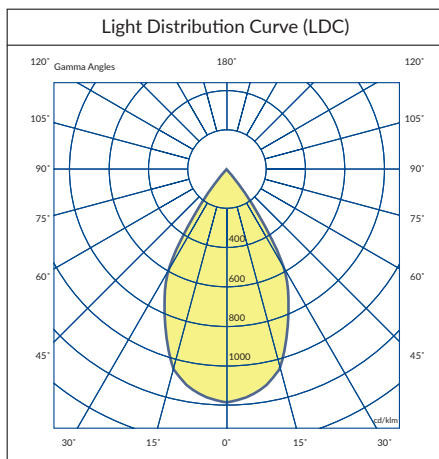

## Dimensions

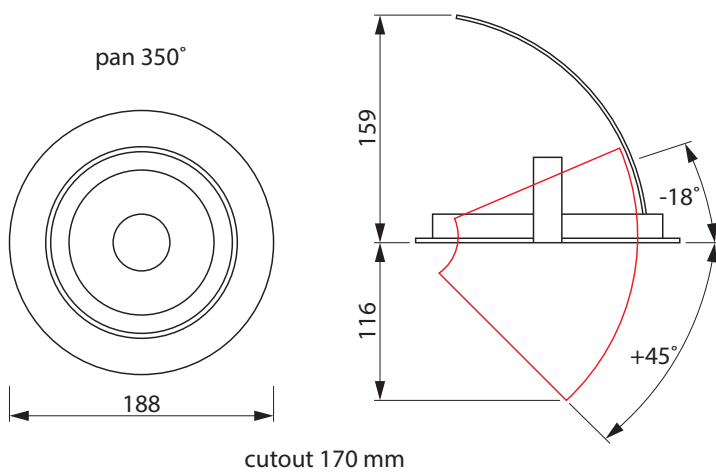

All photometric and electrical data published are of ±10% tolerance. Characteristics and specifications may change without notice. All electrical installations / connections should be carried out by a suitably qualified person. Application images are indicative only and may not contain actual Davis product. The information contained in this publication is typical and must not be interpreted as a guarantee of individual product performance.